

Continuous Gas Analyzer, extractive

CALOMAT 62

General information

Overview



The CALOMAT 62 gas analyzer is primarily used for quantitative determination of one gas component (e.g. H₂, N₂, Cl₂, HCl, NH₃) in binary or quasi-binary gas mixtures.

The CALOMAT 62 is specially designed for use in corrosive gas mixtures.

Benefits

- Universally applicable hardware basis
- Integrated correction of cross-interference, no external calculation required
- Open interface architecture (RS 485, RS 232, PROFIBUS)
- SIPROM GA network for maintenance and servicing information (option)
- Electronics and analyzer unit: gas-tight isolation, purging is possible, IP65, long service life even in harsh environments (field device)

Application

Fields of application

- Chlorine-alkali electrolysis
- Metallurgy (steel production and processing)
- H₂ measurement in LNG (Liquefied Natural Gas) process
- Ammonia synthesis
- Fertilizer production
- Petrochemicals

Special versions

Special applications

In addition to the standard combinations, special applications are also available upon request (e.g. higher sample gas pressure up to 2 000 hPa absolute).

Design

19" rack unit

- With 4HE for installation
 - in hinged frame
 - in cabinets with or without telescope rails
 - With closed or flow-type reference chambers
- Front plate for service purposes can be pivoted down (laptop connection)
- IP20 degree of protection, with purging gas connection
- Internal gas routes: Pipe made of stainless steel (mat. no. 1.4571)
- Gas connections for sample gas inlet and outlet and for reference gas: Internal thread 1/8" – 27 NPT
- Purging gas connections: Pipe diameter 6 mm or 1/4"
- With closed or flow-type reference chambers

Field device

- Two-door enclosure (IP65) for wall mounting with gas-tight separation of analyzer and electronic parts, purgeable
- Individually purgeable enclosure halves
- Gas path with screw pipe connection made of stainless steel (mat. no. 1.4571), or Hastelloy C22
- Purging gas connections: Pipe diameter 10 mm or 3/8"
- Gas connections for sample gas inlet and outlet and for reference gas: Internal thread 1/8" – 27 NPT
- With closed or flow-type reference chambers

Display and control panel

- Large LCD field for simultaneous display of:
 - Measured value (digital and analog displays)
 - Status bar
 - Measuring ranges
- Contrast of the LCD field adjustable via the menu
- Permanent LED backlighting
- Washable membrane keyboard with five softkeys
- Menu-driven operator control for parameterization, test functions, adjustment
- Operator support in plain text
- Graphical display of the concentration progression; time intervals parameterizable
- Bilingual operating software German/English, English/Spanish, French/English, Spanish/English, Italian/English

Input and outputs

- One analog output per medium (from 0, 2, 4 to 20 mA; NAMUR parameterizable)
- Two analog inputs configurable (e.g. correction of cross-interference or external pressure sensor)
- Six binary inputs freely configurable (e.g. measurement range changeover, processing of external signals from the sample preparation)
- Six relay outputs, freely configurable (e.g. failure, maintenance request, threshold alarm, external magnetic valves)
- Each can be expanded by eight additional binary inputs and relay outputs (e.g. for autocalibration with max. four test gases)

Communication

RS 485 present in basic unit (connection from the rear; for the rack unit also behind the front plate).

Options

- RS 485/RS 232 converter
- RS 485/Ethernet converter
- RS 485/USB converter
- Connection to networks via PROFIBUS DP/PA interface
- SIPROM GA software as the service and maintenance tool

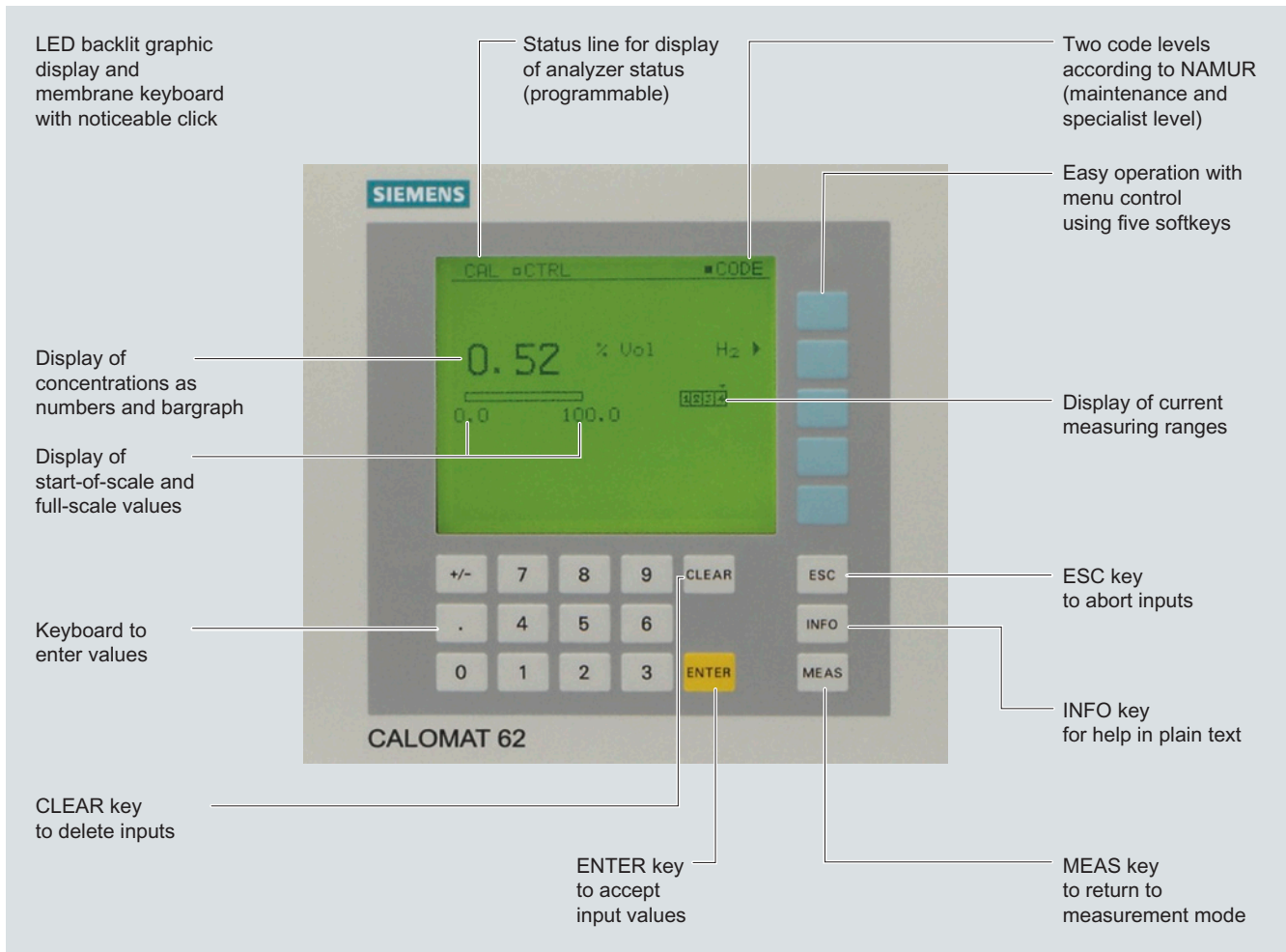

CALOMAT 62, membrane keyboard and graphic display

Designs – parts wetted by sample gas

Gas connection	19" rack unit	Field device
Input block with gas connection	Stainless steel, mat. no. 1.4571	Stainless steel, mat. no. 1.4571
Seal	FPM (e.g. Viton) or FFPM	FPM (e.g. Viton) or FFPM
Sensor	Glass	Glass
Input block with gas connection		Hastelloy C22
Seal		FFPM (e.g. Kalrez)
Sensor		Glass

Continuous Gas Analyzer, extractive CALOMAT 62

General information

2

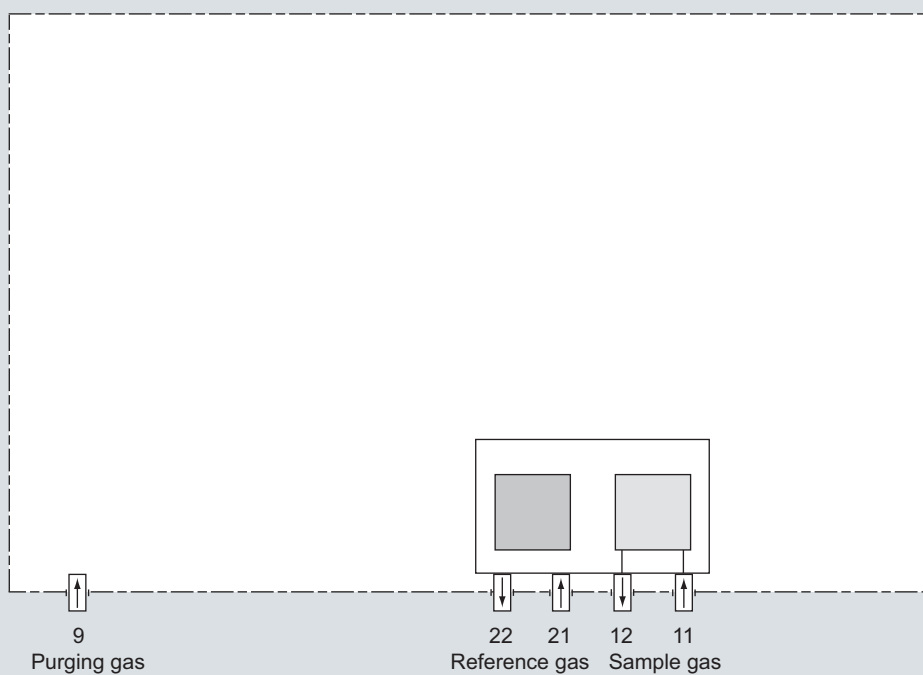

CALOMAT 62, 19" rack unit, gas path

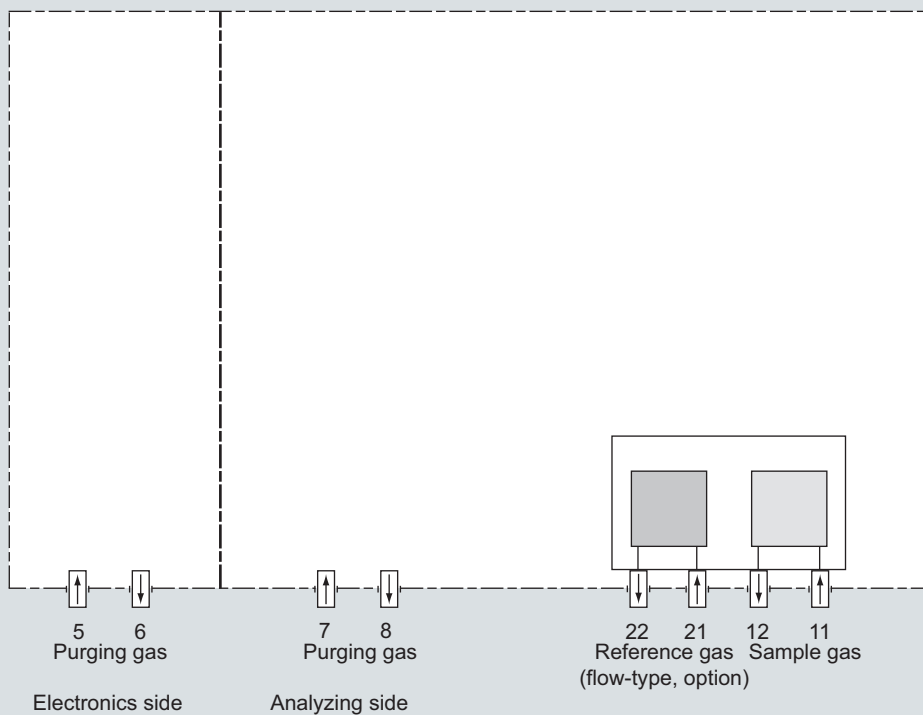

CALOMAT 62, field device, gas path

Function

Principle of operation

The measuring principle is based on the different thermal conductivity of gases.

The temperature of a heated resistor surrounded by gas is determined by the thermal conductivity of the gas. Four such resistors are connected as a bridge.

Sample gas flows around two of them, reference gas surrounds the other two. A constant DC voltage heats the resistors above the temperature of the measurement block.

The different thermal conductivities of the sample and reference gases result in different temperatures of the resistors. A change in the composition of the sample gas thus also causes a change in the resistance values.

The electrical equilibrium of the measuring bridge is disrupted, and a voltage is generated in the bridge diagonal. This is a measure of the concentration of the measured component.

Note

The sample gases must be fed into the analyzers free of oil, grease, and dust. The formation of condensation in the sample chambers (dew point of sample gas < ambient temperature) must be avoided. Therefore, gas prepared for the respective task must be provided in most applications.

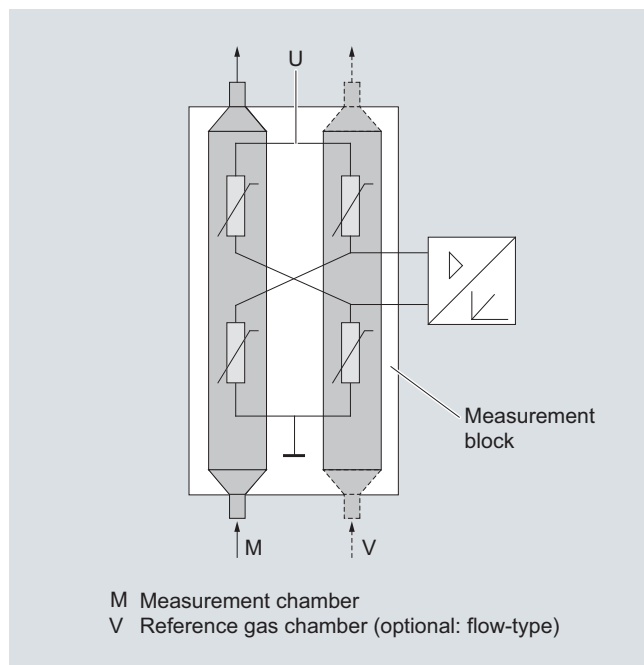

CALOMAT 62, principle of operation, example of a non-flow-type reference chamber

Important features

- Four freely-programmable measuring ranges, also with suppressed zero, all ranges linear
- Smallest spans down to 1 % H₂ (with suppressed zero: 99 to 100 % H₂) possible
- Measuring range identification
- Electrically isolated measured-value output 0/2/4 to 20 mA (also inverted)
- Automatic or manual measuring range switchover selectable; remote switching is also possible
- Measured value can be saved during adjustment
- Time constants are selectable within wide ranges (static/dynamic noise suppression); i.e. the response time of the analyzer can be adapted to the respective task
- Short response time
- Low long-term drift
- Measuring point switchover for up to 6 measuring points (parameterizable)
- Measuring point identification
- External pressure sensor can be connected – for correction of variations in sample gas pressure
- Possibility for correcting the influence of residual gases (correction of cross-interference)
- Automatic measuring range calibration can be programmed
- Operation based on the NAMUR recommendation
- Two operator input levels with their own authorization codes to prevent unintentional and unauthorized interventions
- Simple handling using a numerical membrane keyboard and operator prompting
- Customer-specific device versions, such as:
 - Customer acceptance
 - TAG labels
 - Drift recording
 - Clean for O₂ service

Spans

The smallest and largest possible spans depend on both the measured component (gas type) and the respective application (see ordering data).

Cross-interferences

Information on the sample gas composition is required in order to determine the cross-interference of residual gases with several interfering components.

The zero offsets in % H₂ which result from 1 % residual gas (interfering gas) are listed in the following table; the specified values are approximate values.

It should be noted that the influence of interfering gas is not linear to its concentration. Information on the sample gas composition is required in order to determine the cross-interference of residual gases with several interfering components.

Ar	Approx. - 0.15 %
O ₂	Approx. + 0.02 %
CO ₂	Approx. - 0.13 %
CH ₄	Approx. + 0.17 %
SO ₂	Approx. - 0.31 %
Air (dry)	Approx. + 0.25 %

Effect of 1 % gas component with nitrogen as the residual gas, expressed in % H₂

Moreover, it must be noted that - in addition to a zero offset - the gradient of the characteristic can also be affected by the residual gas. However, this effect is negligible in the case of variations in the interfering gas concentration below 10 %.

Taking these facts into consideration and due to the fact that the cross-interference analyzers cause further measuring inaccuracies, a larger error in measurement occurs than with binary gas mixtures despite correction of cross-interference.

Continuous Gas Analyzer, extractive CALOMAT 62

General information

Specification for the interface cable

Surge impedance	100 ... 300 Ω , with a measuring frequency of > 100 kHz
Cable capacitance	Typ. < 60 pF/m
Core cross-section	> 0.22 mm ² , corresponds to AWG 23
Cable type	Twisted pair, 1 x 2 conductors of cable section
Signal attenuation	Max. 9 dB over the whole length
Shielding	Copper braided shield or braided shield and foil shield
Connection	Pin 3 and pin 8

Bus terminating resistors

Pins 3-7 and 8-9 of the first and last connectors of a bus cable must be bridged (see figure).

Note

It is advisable to install a repeater on the device side in the case of a cable length of more than 500 m or with high interferences.

Up to four components can be corrected via the ELAN bus, correction of cross-interference can be carried out for one or two components via the analog input.

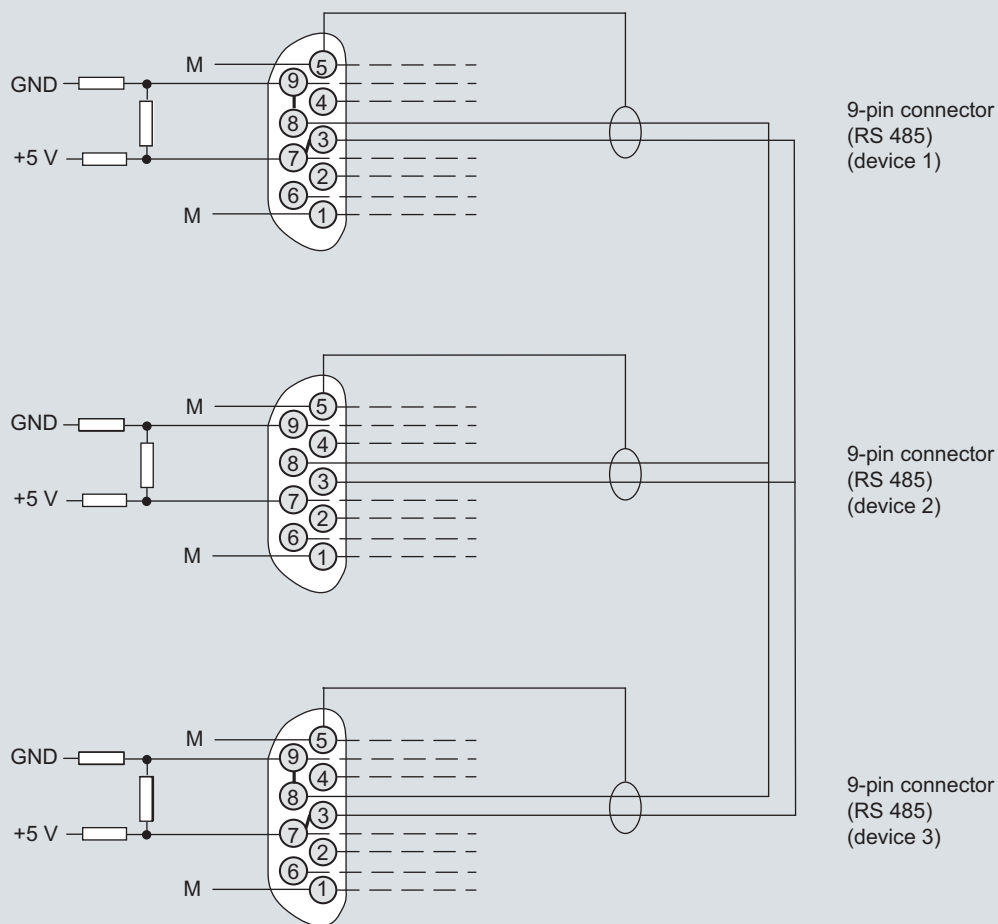

Bus cable with plug connections, example

Technical specifications

General (based on DIN EN 61207/IEC 1207. All data refers to the binary gas mixture H₂ in N₂)

Measuring ranges	4, internally and externally switchable; automatic measuring range switchover also possible
Span	Application-dependent (see ordering data)
Measuring ranges with suppressed zero point	Application-dependent (see ordering data)
Operating position	Front wall, vertical
Conformity	CE marking in accordance with EN 50081-1/EN 50081-2 and RoHS

Design, enclosure

Degree of protection	IP20 according to EN 60529
Weight	Approx. 13 kg

Electrical characteristics

EMC (Electromagnetic Compatibility)	In accordance with standard requirements of NAMUR NE21 (08/98) and EN 61326
Electrical safety	In accordance with EN 61010-1; overvoltage category II
Power supply (see nameplate)	100 V AC -10 % ... 120 V AC +10 %, 47 ... 63 Hz or 200 V AC -10 % ... 240 V AC +10 %, 47 ... 63 Hz
Power consumption	Approx. 30 VA
Fuse values	100 ... 120 V: 1.0T/250 200 ... 240 V: 0.63T/250

Gas inlet conditions

Sample gas pressure	800 ... 1 100 hPa (absolute)
Sample gas flow	30 ... 90 l/h
Sample gas temperature	Min. 0 ... max. 50 °C, but above the dew point
Temperature of the measuring cell	70 °C

Dynamic response (the dynamic and measuring response refers to the measurement of H₂ in N₂)

Warm-up period	< 30 min at room temperature (the technical specification will be met after 2 hours)
Delayed display (T ₉₀)	Approx. 35 s (including dead time)
Damping (electrical time constant)	0 ... 100 s, parameterizable
Dead time (the diffusion to the probes is the determining variable)	Approx. 34 s
Dead time (special application)	< 10 s

Measuring response (the dynamic and measuring response refers to the measurement of H₂ in N₂) (referred to sample gas pressure 1 000 hPa absolute, sample gas flow 0.5 l/min, and ambient temperature 25 °C)

Output signal fluctuation (3σ value)	< ± 1 % of the smallest possible span according to rating plate, with electronic damping constant of 1 s
Zero point drift	< ± 1 % of the current span/week
Measured-value drift	< ± 1 % of the smallest possible span (according to rating plate)/week
Repeatability	< ± 1 % of the current span
Detection limit	1 % of the smallest possible span according to rating plate
Linearity error	< ± 1 % of the current span

Influencing variables (referred to sample gas pressure 1 000 hPa absolute, sample gas flow 0.5 l/min, and ambient temperature 25 °C)

Ambient temperature	< 2 %/10 K referred to smallest possible span according to label
Accompanying gases	Deviation from zero point (for influence of interfering gas, see section "Cross-interference")
Sample gas flow	0.2 % of the current measuring span with a change in flow of 0.1 l/min within the permissible flow range
Sample gas pressure	< 1 % of the current span with a change in pressure of 100 hPa
Power supply	< 0.1 % of the current span with rated voltage ± 10 %

Electrical inputs and outputs

Analog output	0/2/4 ... 20 mA, isolated; max. load 750 Ω
Relay outputs	6, with changeover contacts, freely parameterizable, e.g. for measuring range identification; load: 24 V AC/DC/1 A, isolated
Analog inputs	2, dimensioned for 0/2/4 ... 20 mA for external pressure sensor and correction of cross-interference
Binary inputs	6, designed for 24 V, isolated, freely parameterizable, e.g. for measuring range switchover
Serial interface	RS 485
Options	AUTOCAL function with 8 additional binary inputs and 8 additional relay outputs, also with PROFIBUS PA (on request) or PROFIBUS DP (on request)

Climatic conditions

Permissible ambient temperature	-40 ... +70 °C during storage and transportation, 5 ... 45 °C during operation
Permissible humidity (dew point must not be fallen below)	< 90 % relative humidity as annual average, during storage and transportation

Continuous Gas Analyzer, extractive

CALOMAT 62

19" rack unit

2

Selection and ordering data**Order No.****CALOMAT 62 gas analyzer**

D) 7MB2541- - A

19" rack unit for installation in cabinets

Material of sample gas path

Stainless steel, mat. no. 1.4571; Purging gas stub 6 mm

non-flow-type reference chamber, 1/8"-27 NPT

Stainless steel, mat. no. 1.4571; Purging gas stub 1/4"

non-flow-type reference chamber, 1/8"-27 NPT

ApplicationPossible with measuring range identificationH₂ in N₂

0; 5

AN

SO₂ in air

1; 6

EL

CO₂ in H₂

0; 5

KA

CO₂ in N₂

1; 6

KN

Smallest measuring rangeLargest measuring rangeReference gas or filling gas

0 ... 1 %

0 ... 100 %

0

0 ... 5 %

0 ... 100 %

1

0 ... 5 %

0 ... 60 %

Accompanying gas component

2

0 ... 10 %

0 ... 100 %

3

0 ... 20 %

0 ... 40 %

4

100 ... 99 %

100 ... 0 %

5

100 ... 95 %

100 ... 0 %

Sample gas component

6

100 ... 90 %

100 ... 0 %

7

100 ... 80 %

100 ... 60 %

8

Add-on electronics

Without

AUTOCAL function

- With 8 additional binary inputs and outputs
- With 8 additional 8 binary inputs/outputs and PROFIBUS PA interface
- With 8 additional binary inputs/outputs and PROFIBUS DP interface

0

1

6

7

Power supply

100 ... 120 V AC, 47 ... 63 Hz

200 ... 240 V AC, 47 ... 63 Hz

0

1

Explosion protection

Without

A

Language (supplied documentation, software)

German

English

French

Spanish

Italian

0

1

2

3

4

Additional versions**Order code**

Add "-Z" to Order No. and specify order codes.

TAG labels (specific inscription based on customer information)

B03

Clean for O₂ service (specially cleaned gas path)

Y02

Measuring range indication in plain text, if different from the standard setting

Y11

Special setting (only in conjunction with an application no., e.g. extended measuring range)

Y12

Extended special setting (only in conjunction with an application no., e.g. determination of cross-interferences)

Y13

Retrofitting sets**Order No.**

RS 485/Ethernet converter

A5E00852383

RS 485/RS 232 converter

C79451-Z1589-U1

RS 485/USB converter

A5E00852382

AUTOCAL function with 8 binary inputs/outputs

C79451-A3480-D511

AUTOCAL function with 8 binary inputs/outputs and PROFIBUS PA

A5E00057307

AUTOCAL function with 8 binary inputs/outputs and PROFIBUS DP

A5E00057312

D) Subject to export regulations AL: 91999, ECCN: N

Continuous Gas Analyzer, extractive CALOMAT 62

19" rack unit

Dimensional drawings

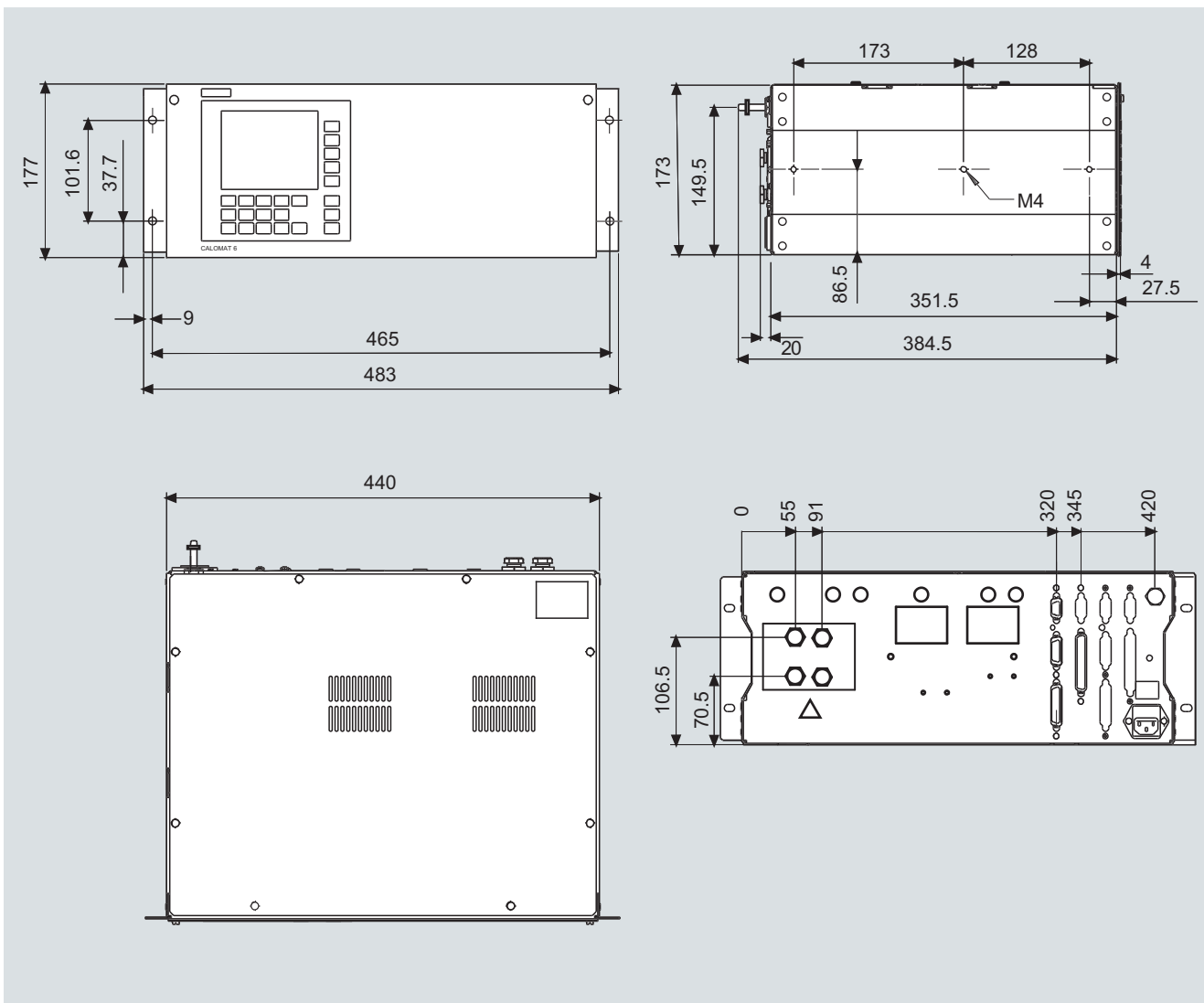

CALOMAT 62, 19" rack unit, dimensions in mm

2

Continuous Gas Analyzer, extractive CALOMAT 62

19" rack unit

Schematics

Pin assignment (electrical and gas connections)

2

Connector SUB-D 9F (RS 485)

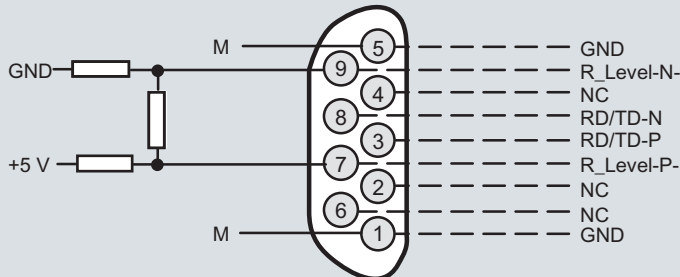

It is possible to connect bus terminating resistors to pins 7 and 9.

SUB-D 15F connector

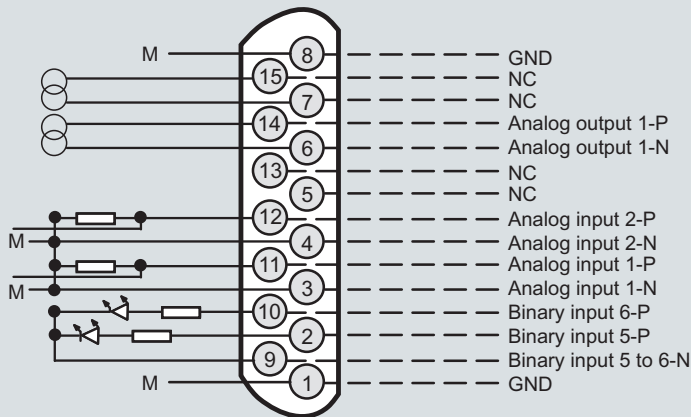

Analog outputs isolated (also from each other), $R_L \leq 750 \Omega$

Correction of pressure or cross-interference
Correction of cross-interference
Correction of cross-interference

Analog inputs non-isolated, 0 ... 20 mA/500 Ω or 0 ... 10 V (low resistance)

SUB-D 25F connector

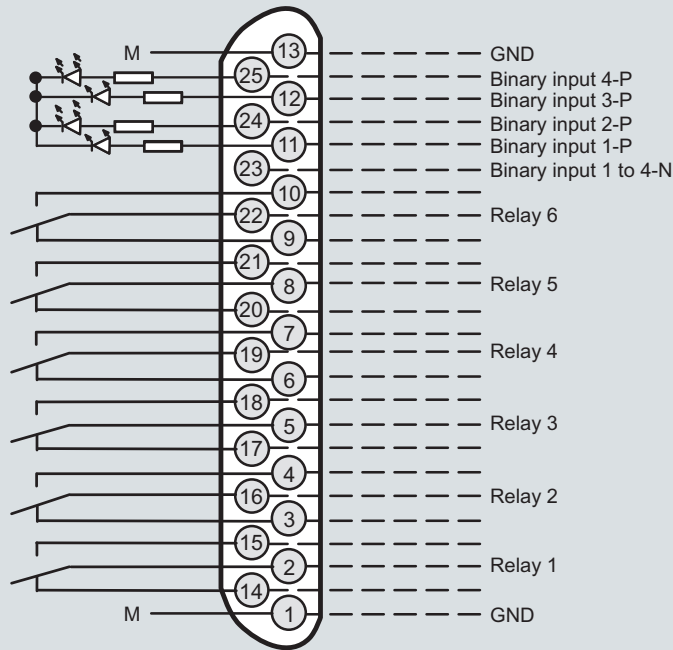

Isolated via optocoupler
"0" = 0 V (0 ... 4.5 V)
"1" = 24 V (13 ... 33 V)

Contact load max. 24 V/1 A, AC/DC
relay contacts shown:
relay coil has zero current

Note:
All cables to the connectors or terminal blocks must be shielded and rest against the enclosure potential.

CALOMAT 62, 19" rack unit, pin assignment

Continuous Gas Analyzer, extractive CALOMAT 62

19" rack unit

2

Connector SUB-D 37F (option)

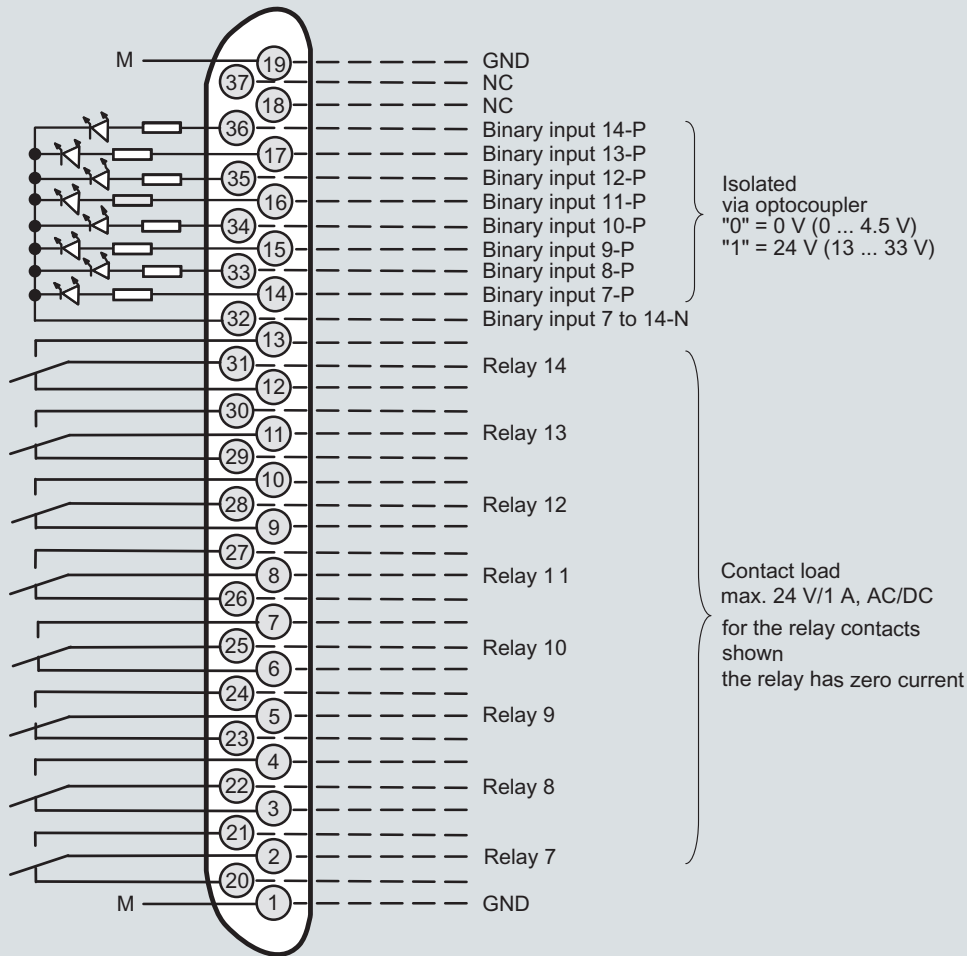

Connector SUB-D 9F PROFIBUS DP

optional

Connector SUB-D 9M PROFIBUS PA

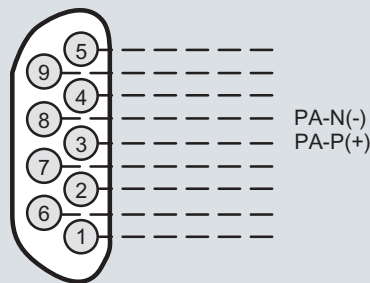
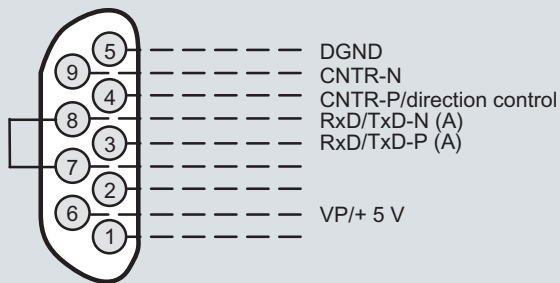

Note:
All cables to the connectors or terminal blocks must be shielded and rest against the enclosure potential.

CALOMAT 62, 19" rack unit, pin assignment of the AUTOCAL board and PROFIBUS connectors

Continuous Gas Analyzer, extractive CALOMAT 62

19" rack unit

2

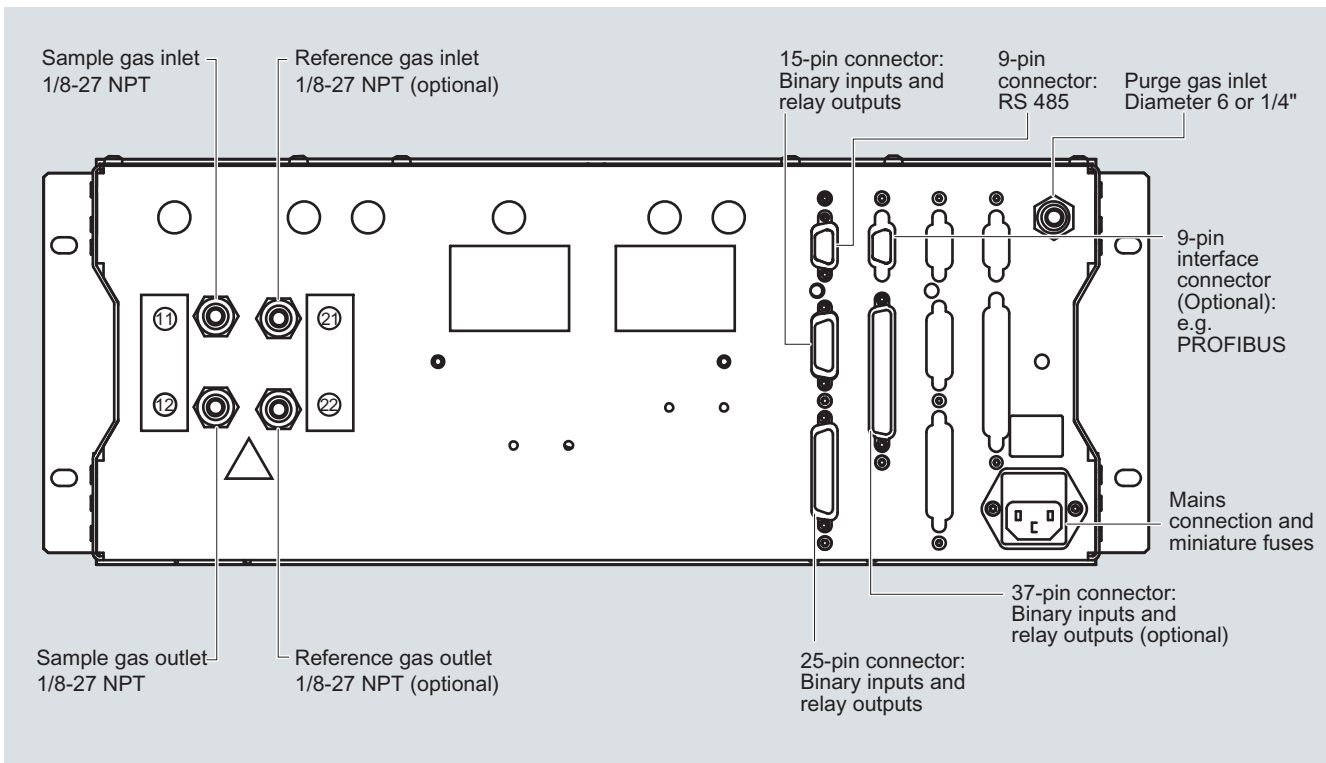

CALOMAT 62, 19" rack unit, gas connections and electrical connections

Technical specifications

General (based on DIN EN 61207/IEC 1207. All data refers to the binary gas mixture H₂ in N₂)

Measuring ranges	4, internally and externally switchable; automatic measuring range switchover also possible
Span	Application-dependent (see ordering data)
Measuring ranges with suppressed zero point	Application-dependent (see ordering data)
Operating position	Front wall, vertical
Conformity	CE marking in accordance with EN 50081-1/EN 50081-2 and RoHS

Design, enclosure

Degree of protection	IP65 according to EN 60529
Weight	Approx. 25 kg

Electrical characteristics

EMC (E lectromagnetic C ompatibility)	In accordance with standard requirements of NAMUR NE21 (08/98) and EN 61326
Electrical safety	In accordance with EN 61010-1; overvoltage category II
Power supply (see nameplate)	100 AC -10 % ... 120 V AC +10 %, 47 ... 63 Hz or 200 AC -10 % ... 240 V AC +10 %, 47 ... 63 Hz
Power consumption	<ul style="list-style-type: none"> • Approx. 25 VA (gas connection block unheated) • Approx. 330 VA (gas connection block heated)
Fuse values (gas connection unheated)	100 ... 120 V F3 1T/250 F4 1T/250 200 ... 240 V F3 0.63T/250 F4 0.63T/250
Fuse values (gas connection heated)	100 ... 120 V F1 1T/250 F2 4T/250 F3 4T/250 F4 4T/250 200 ... 240 V F1 0.63T/250 F2 2.5T/250 F3 2.5T/250 F4 2.5T/250

Gas inlet conditions

Sample gas pressure	800 ... 1 100 hPa (absolute)
Sample gas flow	30 ... 90 l/h
Sample gas temperature	Min. 0 ... max. 50 °C, but above the dew point
Temperature	
• of the measuring cell (sensor)	70 °C
• of the measuring cell block (base)	80 °C (heated)
Sample gas humidity	< 90 % relative humidity
Purging gas pressure	
• Permanent	165 hPa above ambient pressure
• For short periods	Max. 250 hPa above ambient pressure

Dynamic response (the dynamic and measuring response refers to the measurement of H₂ in N₂) (referred to sample gas pressure 1 000 hPa absolute, sample gas flow 0.5 l/min, and ambient temperature 25 °C)

Warm-up period	< 30 min at room temperature (the technical specification will be met after 2 hours)
Delayed display (T ₉₀)	Approx. 35 s (including dead time)
Electrical damping	0 ... 100 s, parameterizable
Dead time (the diffusion to the probes is the determining variable)	Approx. 34 s

Measuring response (the dynamic and measuring response refers to the measurement of H₂ in N₂) (referred to sample gas pressure 1 000 hPa absolute, sample gas flow 0.5 l/min, and ambient temperature 25 °C)

Output signal fluctuation (3σ value)	< ± 1 % of the smallest possible span according to rating plate with electronic damping constant of 1 s
Zero point drift	< ± 1 % of the current span/week
Measured-value drift	< ± 1 % of the smallest possible span (according to rating plate)/week
Repeatability	< ± 1 % of the current span
Detection limit	1 % of the smallest possible span according to rating plate
Linearity error	< ± 1 % of the current span

Influencing variables (referred to sample gas pressure 1 000 hPa absolute, sample gas flow 0.5 l/min, and ambient temperature 25 °C)

Ambient temperature	< 2 %/10 K referred to smallest possible span according to rating plate
Accompanying gases	Deviation from zero point (for influence of interfering gas, see section "Cross-interference")
Sample gas flow	0.2 % of the current measuring span with a change in flow of 0.1 l/min within the permissible flow range
Sample gas pressure	< 1 % of the span with a change in pressure of 100 hPa
Power supply	< 0.1 % of the output signal span with rated voltage ± 10 %

Electrical inputs and outputs

Analog output	0/2/4 ... 20 mA, isolated; max. load 750 Ω
Relay outputs	6, with changeover contacts, freely parameterizable, e.g. for measuring range identification; load: 24 V AC/DC/1 A, isolated
Analog inputs	2, dimensioned for 0/2/4 ... 20 mA for external pressure sensor and correction of cross-interference
Binary inputs	6, designed for 24 V, isolated, freely parameterizable, e.g. for measuring range switchover
Serial interface	RS 485
Options	AUTOLOCAL function with 8 additional binary inputs and 8 additional relay outputs, also with PROFIBUS PA (on request) or PROFIBUS DP (on request)

Climatic conditions

Permissible ambient temperature	-40 ... +70 °C during storage and transportation, 5 ... 45 °C during operation
Permissible humidity (dew point must not be fallen below)	< 90 % relative humidity as annual average, during storage and transportation

Continuous Gas Analyzer, extractive

CALOMAT 62

Field device

Selection and ordering data

CALOMAT 62 gas analyzer for field installation

Order No.

D) 7MB2531- - - - - Cannot be combined

Material of sample gas path

 Stainless steel, mat. no. 1.4571; Purging gas stub 10 mm
 non-flow-type reference chamber, 1/8"-27 NPT
 Hastelloy C22; non-flow-type reference chamber, 1/8"-27 NPT
 Hastelloy C22; flow-type reference chamber, 1/8"-27 NPT

 0
 2
 3

 0
 3
 4

 Stainless steel, mat. no. 1.4571; Purging gas stub $\frac{3}{8}$ "
 non-flow-type reference chamber, 1/8"-27 NPT
 Hastelloy C22; non-flow-type reference chamber, 1/8"-27 NPT
 Hastelloy C22; flow-type reference chamber, 1/8"-27 NPT

 4
 6
 7

 4
 7

Application

Possible with measuring range identification

H ₂ in N ₂	0; 5	AN	AN
H ₂ in Cl ₂	0; 5	AB	AB
H ₂ in HCl	0; 5	AC	AC
Cl ₂ in air	1; 6	BL	BL
Cl ₂ in HCl	3; 7	BC	BC
HCl in air	1; 6	CL	CL
NH ₃ in N ₂	4; 8	DN	DN
SO ₂ in air	1; 6	EL	EL
CO ₂ in H ₂	0; 5	KA	KA
CO ₂ in N ₂	1; 6	KN	KN

 AN
 AB
 AC
 BL
 BC
 CL
 DN
 EL
 KA
 KN

Smallest measuring range

Largest measuring range

Reference gas or filling gas

0 ... 1 %	0 ... 100 %	0	0
0 ... 5 %	0 ... 100 %	1	1
0 ... 5 %	0 ... 60 %	2	2
0 ... 10 %	0 ... 100 %	3	3
0 ... 20 %	0 ... 40 %	4	4
100 ... 99 %	100 ... 0 %	5	5
100 ... 95 %	100 ... 0 %	6	6
100 ... 90 %	100 ... 0 %	7	7
100 ... 80 %	100 ... 60 %	8	8

 0
 1
 2
 3
 4
 5
 6
 7
 8

 Accompanying gas
component

Sample gas component

Add-on electronics

 Without
 AUTOCAL function
 • With 8 additional binary inputs/outputs
 • With 8 additional binary inputs/outputs and PROFIBUS PA interface
 • With 8 additional binary inputs/outputs and PROFIBUS DP interface

 0
 1
 6
 7

Power supply

 100 ... 120 V AC, 47 ... 63 Hz
 200 ... 240 V AC, 47 ... 63 Hz

 0
 1

Heating of internal gas paths and analyzer unit

 Without
 With (max. 80 °C)

 A
 B

Explosion protection

 Without
 According to ATEX II 2G, leakage compensation¹⁾
 According to ATEX II 2G, continuous purging¹⁾

 A
 E
 F

Language (supplied documentation, software)

 German
 English
 French
 Spanish
 Italian

 0
 1
 2
 3
 4

D) Subject to export regulations AL: 91999, ECCN: N

¹⁾ Only in connection with an approved purging unit.

2

Selection and ordering data

<i>Additional versions</i>	Order code
Add "-Z" to Order No. and specify order codes.	
TAG labels (specific inscription based on customer information)	B03
Clean for O ₂ service (specially cleaned gas path)	Y02
Measuring range indication in plain text, if different from the standard setting	Y11
Special setting (only in conjunction with an application no., e.g. extended measuring range)	Y12
Extended special setting (only in conjunction with an application no., e.g. determination of cross-interferences)	Y13
<i>Retrofitting sets</i>	Order No.
RS 485/Ethernet converter	A5E00852383
RS 485/RS 232 converter	C79451-Z1589-U1
RS 485/USB converter	A5E00852382
AUTOCAL function with 8 binary inputs/outputs	A5E00064223
AUTOCAL function with 8 binary inputs/outputs and PROFIBUS PA	A5E00057315
AUTOCAL function with 8 binary inputs/outputs and PROFIBUS DP	A5E00057318

Continuous Gas Analyzer, extractive CALOMAT 62

Field device

Dimensional drawings

2

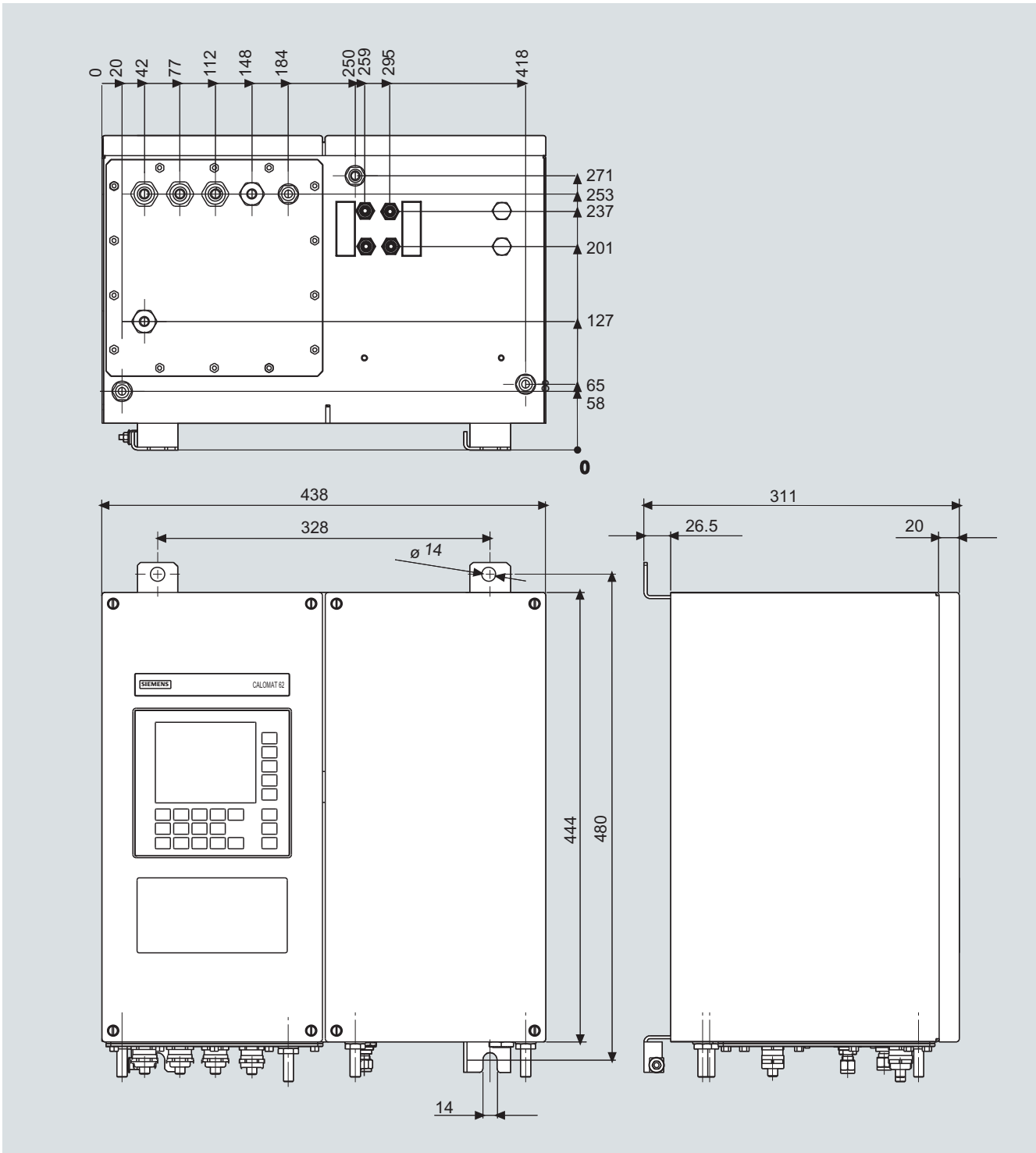

CALOMAT 62, field device, dimensions in mm

Schematics

Pin assignment (electrical and gas connections)

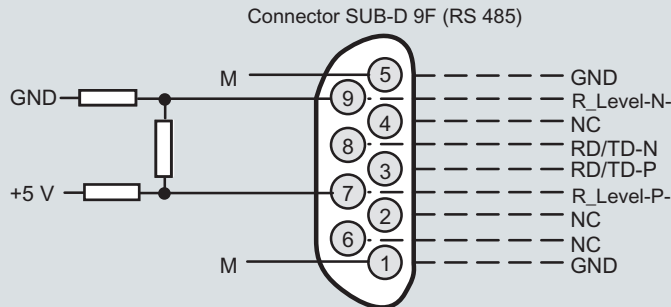

It is possible to connect bus terminating resistors to pins 7 and 9.

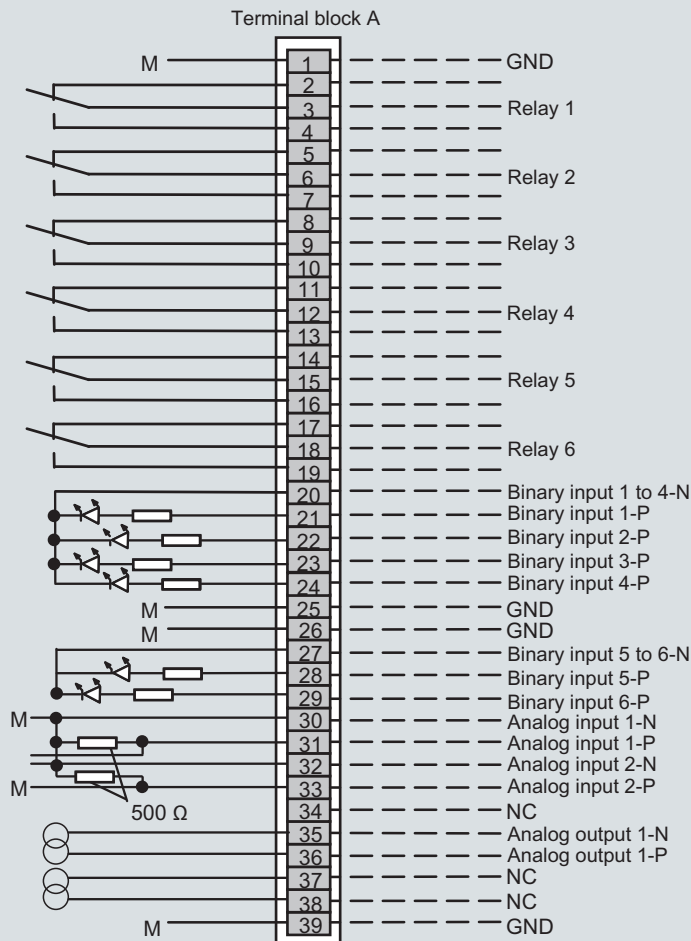

Contact load max.
24 V/1 A, AC/DC; relay contacts shown: relay coil has zero current

Isolated via optocoupler
"0" = 0 V (0 ... 4.5 V)
"1" = 24 V (13 ... 33 V)

Isolated via optocoupler
"0" = 0 V (0 ... 4.5 V)
"1" = 24 V (13 ... 33 V)
} Correction of cross-interference } Analog inputs non-isolated,
} Pressure correction } 0 ... 20 mA or 0 ... 10 V (internal resistance ≤ 500 Ω)

} Analog outputs isolated

Note:
All cables to the connectors or terminal blocks must be shielded and rest against the enclosure potential.

CALOMAT 62, field device, pin and terminal assignment

Continuous Gas Analyzer, extractive CALOMAT 62

Field device

2

Terminal block B (option)

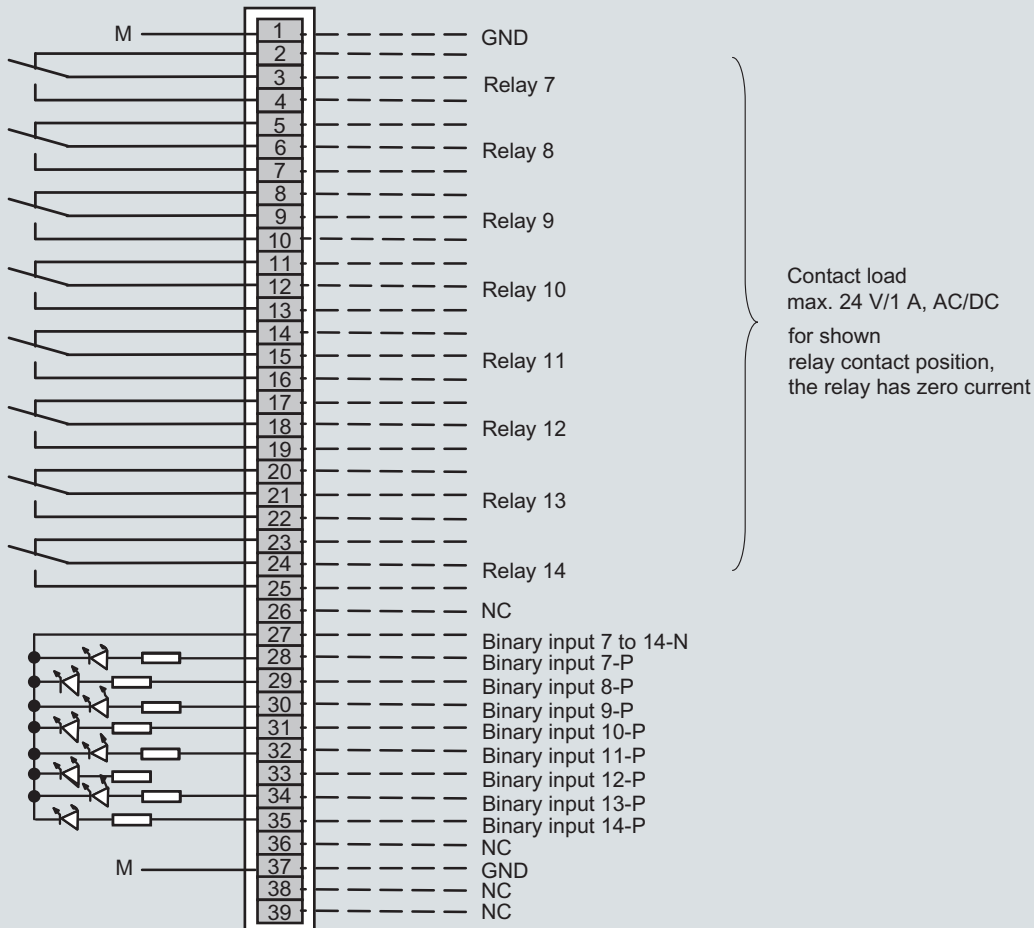

Connector SUB-D 9F-X90
PROFIBUS DP

optional

Connector SUB-D 9M-X90
PROFIBUS PA

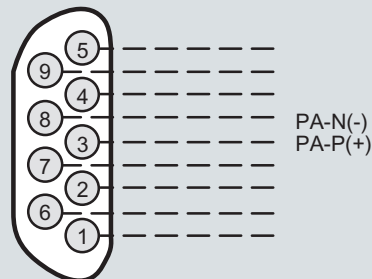
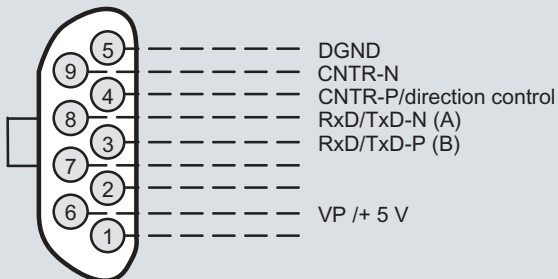

Note:
All cables to the connectors or terminal blocks must be shielded and rest against the enclosure potential.

CALOMAT 62, field device, pin and terminal assignment of the AUTOCAL board and PROFIBUS connectors

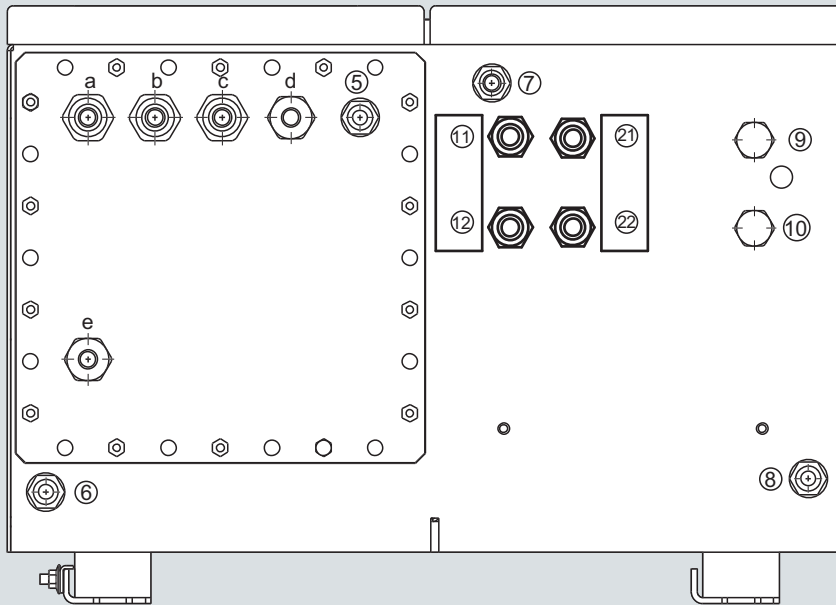

Gas connections

- | | | |
|-----|--------------------------|------------------------------------|
| ① | Sample gas inlet | } Internal thread
1/8" - 27 NPT |
| ⑫ | Sample gas outlet | |
| ⑳ | Reference gas inlet | |
| ㉒ | Reference gas outlet | |
| ⑤-⑧ | Purge gas inlets/outlets | Fittings Ø 10 mm or 3/8" |
| ⑨ | Unassigned | |
| ⑩ | Unassigned | |

Electrical connections

- | | |
|-------|--|
| a - c | Signal cable (Ø 10 ... 14 mm)
(analog + digital); cable gland M20x1.5 |
| d | Interface connection: (Ø 7 ... 12 mm)
cable gland M20x1.5 |
| e | Power supply: (Ø 7 ... 12 mm)
cable gland M20x1.5 |

CALOMAT 62, field device, gas connections and electrical connections

Continuous Gas Analyzer, extractive

CALOMAT 62

Documentation

Selection and ordering data

Operating instructions	Order No.
CALOMAT 62 Thermal conductivity gas analyzer	
• German	A5E00881392
• English	A5E00881393
• French	A5E00881395
• Italian	A5E00881398
• Spanish	A5E00881396
Gas analyzers of Series 6 and ULTRAMAT 23 PROFIBUS DP/ PA interface	
• German and English D)	A5E00054148

D) Subject to export regulations AL: 9I999, ECCN: N

Suggestions for spare parts

Selection and ordering data

Description	7MB2541	7MB2531	2 years (quantity)	5 years (quantity)	Order No.
Temperature limiter		x	–	1	A5E00891855
Adapter plate, LC display/keypad	x	x	1	1	C79451-A3474-B605
Temperature sensor		x	–	1	C79451-A3480-B25
LC display	x		–	1	W75025-B5001-B1
Line transformer, 115 V	x	x	–	1	W75040-B21-D80
Line transformer, 230 V	x	x	–	1	W75040-B31-D80
Fuse, T 0.63 A, line voltage 200 to 240 V	x	x	2	3	W79054-L1010-T630
Fuse, T 1 A, line voltage 100 ... 120 V	x	x	2	3	W79054-L1011-T100
Heating cartridge		x	–	1	W75083-A1004-F120